

stûv

Pellets

The
essential
fire

With the focus firmly on technology, Stûv's pellet stoves combine elegance, excellent performance and respect for the environment. They stand out thanks to the shape of their combustion chamber, built around one continuous line (ligne continue®), maximising your view of the fire. The quality of the generous, full flames and their radiation is comparable to that of a wood-burning fire. Their CO and fine particle emissions are virtually undetectable; their performance is exceptional. As well as these unique qualities, which are down to our patented technology, these stoves make no noise at all and are incredibly easy to use and maintain.

pellet stoves

free-standing devices so installation
requires no finishing work

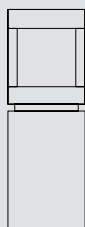

s[P10] p.2

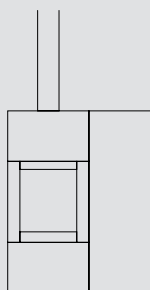

s[P20]B p.14

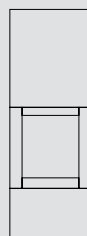

s[P20]S p.22



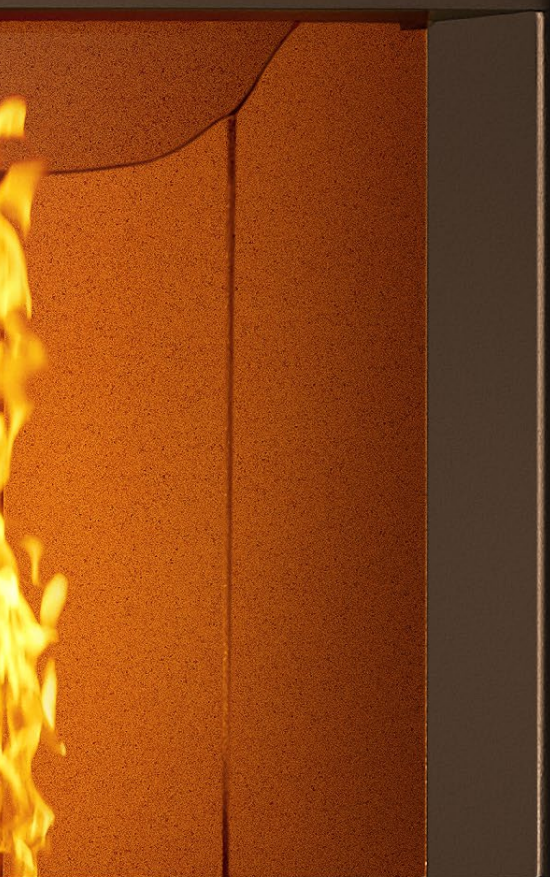



When you choose Stûv, you're reaping the rewards of impressive savoir-faire and innovative technology.

s[P10]



The sP10 really stands out from the crowd thanks to the two elements of its design. The combustion chamber makes up the top of the stove, using natural convection and radiation to provide the heat. It can be angled manually, and features a wide glass front, so there is always a beautiful view of the fire.

The sP10's technical features are fitted in the base, which comes in different steel and wood finishes. The stove can be pre-programmed and, once set up, can be controlled remotely.

Performance*

Energy efficiency class

Energy efficiency index

Output

Output range

Nominal efficiency

Seasonal efficiency

Fine particle emissions

CO emissions

NOx emissions

COV/COG emissions

Pellet consumption

s[P10]

Weight

Standards

A++

130

8,1 kW

3,7 - 8,1 kW

92 %

89 %

11,9 mg/Nm³

0,002 % / 20 mg/Nm³

79 mg/Nm³

< 1 mg/Nm³

1,90 kg/h



reddot design award
winner 2016



175 kg

EcoDesign 2022



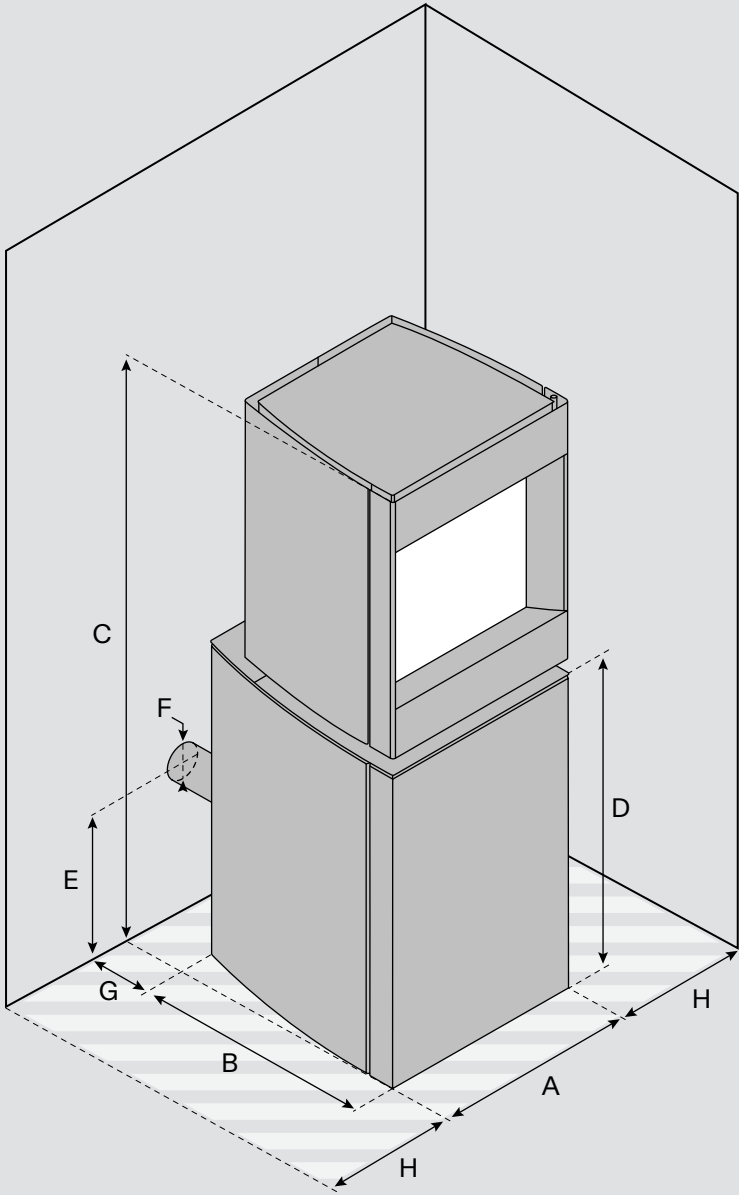

s[P10]

[A] Width	480 mm
[B] Depth	565 mm
[C] Height	1400 mm
[D] Shelf height	760 mm
[E] Smoke outlet height	251 mm
[F] Smoke outlet diameter	80 mm
[G] Rear safety distance	100 mm
[H] Minimum side clearance	100 mm
Ø External air outlet	60 mm
Optional fan kit	-
Colours	Stûv Grey, Stûv Black

Glass

Width	367 mm
Height	370 mm



Finishing panels



Steel
sP10 Stûv Grey



Dark oak*
sP10 Stûv Grey



Bleached oak*
sP10 Stûv Grey



Steel
sP10 Stûv Black



Dark oak*
sP10 Stûv Black



Bleached oak*
sP10 Stûv Black

* Each item is unique and made from natural materials. As a result, slight colour variations may occur between different finish panels. There may also be a slight difference in colour between your product and the one displayed at your local retailer.

Accessories

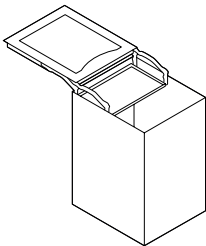

Mobilobox



Remote control



Pellet Twin Set



s[P10]

[SIMPLE] Simplicity is the keyword when it comes to designing our products. This is true of their shape, installation, usage and maintenance. [UNIQUE]

Its bold look makes the sP10 an unusual model, turning it into a striking feature in any home.

[INNOVANT] The patented

“flower burner” system shapes the flames. The result is calm, sculptural, colourful and the perfect size, similar to the effect of burning logs. [SUSTAINABLE] The highly efficient combustion process generates negligible fine particle and CO emissions. Official tests have been carried out by independent specialist laboratories to prove this. [ERGONOMIC] The loading hatch, at the bottom of the device, means that pellets can be added at hip height. The ash pan has been designed for ease of use. [SILENT] The heat is distributed thanks to natural convection and radiation, so there is no blower noise. The pellets are loaded upwards, so they can't fall. [SMART] You can control the device remotely thanks to the Stûv app. It can also be controlled via an integrated display panel or an optional remote control. [AWARD-WINNING] The sP10 has won a Red Dot Award for Product Design, highlighting its technological, aesthetic, environmental and ergonomic qualities. It was chosen from 5,200 products from 57 countries.

**Bold and
effective**



When you choose Stûv, you get front-row seats for the beauty of your fire.

s[P20]B

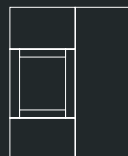

The sP20-B is small but mighty. This low, slimline model still manages to incorporate a hopper capable of storing 32 kg of pellets, maximising its burn time.

The hot air is distributed thanks to natural convection. As an optional extra, the device can be fitted with a ductable convection kit that directs some of the heated air thanks to a fan with 4 power levels.

Performance*

Energy efficiency class

Energy efficiency index

Output

Output range

Nominal efficiency

Seasonal efficiency

Fine particle emissions

CO emissions

NOx emissions

COV/COG emissions

Pellet consumption

s[P20]B

Weight

Standards

A+

129

8,5 kW

3,7 - 8,5 kW

90,9 %

87,7 %

5,1 mg/Nm³

0,0008 % / 10 mg/Nm³

99 mg/Nm³

<1 mg/Nm

1,93 kg/h



reddot winner 2025



157 kg

EcoDesign 2022



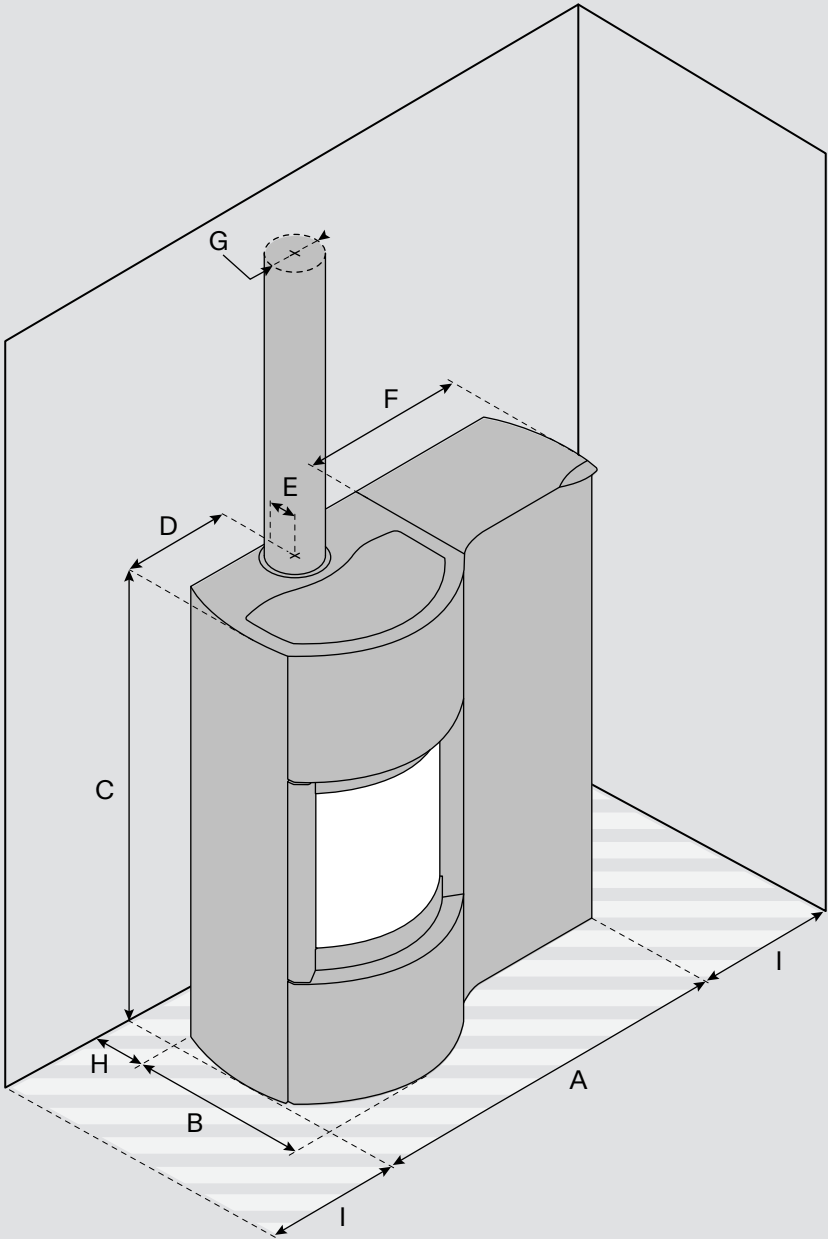

s[P20]B

[A] Width	972 mm
[B] Depth	465 mm
[C] Height	1190 mm
[D] Flue axis - side	278 mm
[E] Flue axis - back	92 mm
[F] Hopper width	435 mm
[G] Smoke outlet diameter	80 - 130 mm
[H] Rear safety distance	unknown
[I] Minimum side clearance	unknown
Ø External air outlet	60 mm
Optional ductable convection kit	✓
Colours	Stûv Black

Glass

Width	375 mm
Height	405 mm







When you choose Stûv, satisfaction is guaranteed.

s[P20]S



The sP20-S really makes a mark even in large spaces. Its large curved glass amplifies the experience of the flames as well as the stove's radiation. It offers the benefits of an efficient pellet burner while producing a similar heat to that of a wood burner.

The sP20-S is a pleasure to use. It burns for up to 21 hours and the automatic de-ashing system keeps maintenance to a minimum. Both smart and monitored, it can be operated remotely.

Performance*

Energy efficiency class

Energy efficiency index

Output

Output range

Nominal efficiency

Seasonal efficiency

Fine particle emissions

CO emissions

NOx emissions

COV/COG emissions

Pellet consumption

s[P20]S

Weight

Standards

A+

128

8,1 kW

3,7-8,1 kW

90,3 %

87 %

6 mg/Nm³

0,003 % / 4 mg/Nm³

89 mg/Nm³

<1 mg/Nm

0,84-1,84 kg/h



180 kg

EcoDesign 2022



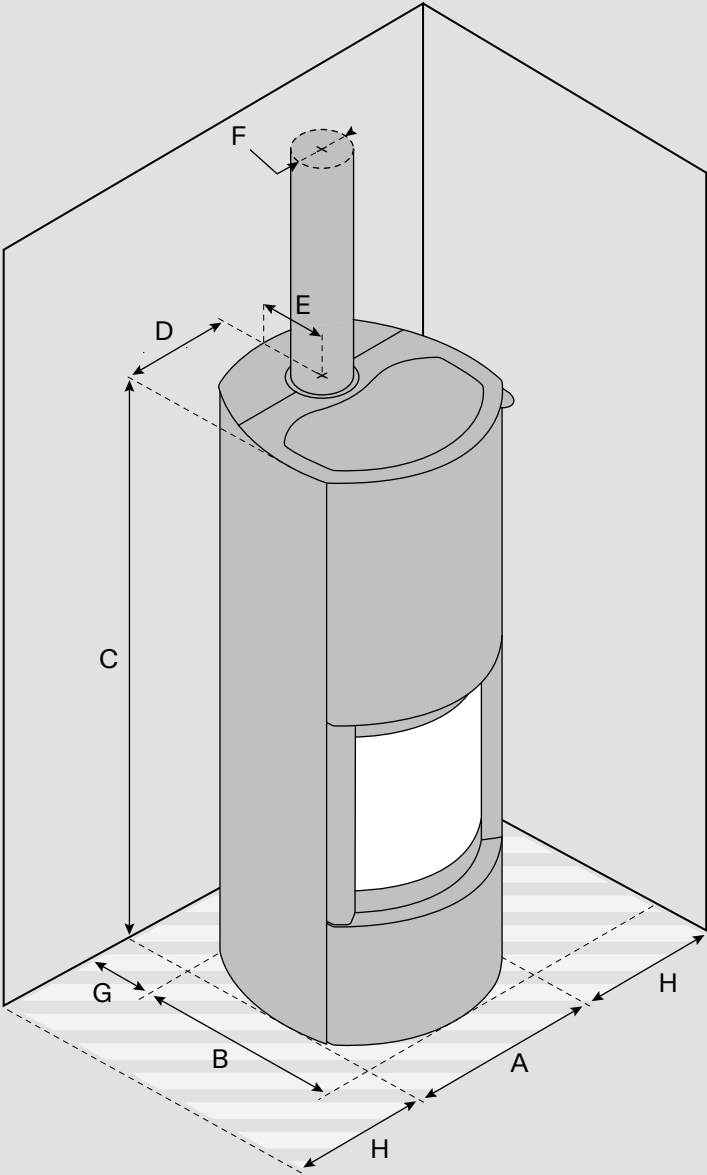

s[P20]S

[A] Width	556 mm
[B] Depth	591 mm
[C] Height	1509 mm
[D] Flue axis - side	278 mm
[E] Flue axis - back	177 mm
[F] Smoke outlet diameter	80 - 130 mm
[G] Rear safety distance	100 mm
[H] Minimum side clearance	100 mm
Ø External air outlet	60 mm
Colours	Stûv Black

Glass

Width	375 mm
Height	405 mm







Accessories

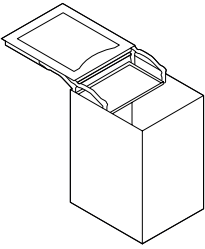

Mobilobox



Remote control

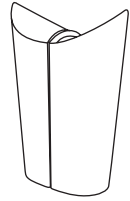

Pellet Twin Set

REMOVE

FUNCTIONS



s[P20]

[SIMPLE] Simplicity is the keyword when it comes to designing our products. This is true of their shape, installation, usage and maintenance. [EFFICIENT] The sP20's energy efficiency is over 90% and its radiation is amplified thanks to its expansive glass surface. [INNOVANT] The

patented "flower burner" system shapes the flames. The result is calm, sculptural, colourful and the perfect size, similar to the effect of burning logs. [SUSTAINABLE] The highly efficient combustion process generates negligible fine particle and CO emissions. Official tests have been carried out by independent specialist laboratories to prove this. [ERGONOMIC] The sP20 loading system has been meticulously designed to make it easier to add the pellets. Both models incorporate a wide hatch. On the sP20-S, it is at the front, at chest height. On the sP20-B, it is at the top of the device, and comes with a bag. [LONG LASTING] The impressive burn time is thanks to the large hopper and ash pan. [SILENT] The heat is distributed thanks to natural convection and radiation, so there is no blower noise. The pellets are loaded upwards, so they can't fall. [SMART] The mobile app offers full remote control. Our monitoring system oversees the operating of your device safely, as well as any maintenance.

The Stûv families

s[6]



s[16]



s[30]



s[μ M]



s[21]



s[22]



s[P10]



s[P20]





Documents and photos are not contractual. Stûv reserves the right to make changes without notice.
This catalogue has been carefully compiled; however, we decline all responsibility for any errors.

Stûv fireplaces are designed and manufactured by Stûv sa - Belgium - stuv.com